

A PLAT OF PARCEL 60 AT THE MEADOWS

BEING PLAT NO. 50 OF MARTIN DOWNS A P.U.D.
LYING IN SECTION 12, TOWNSHIP 38 SOUTH, RANGE 40 EAST
MARTIN COUNTY, FLORIDA.

SHEET 4 OF 4

FEBRUARY, 1989.

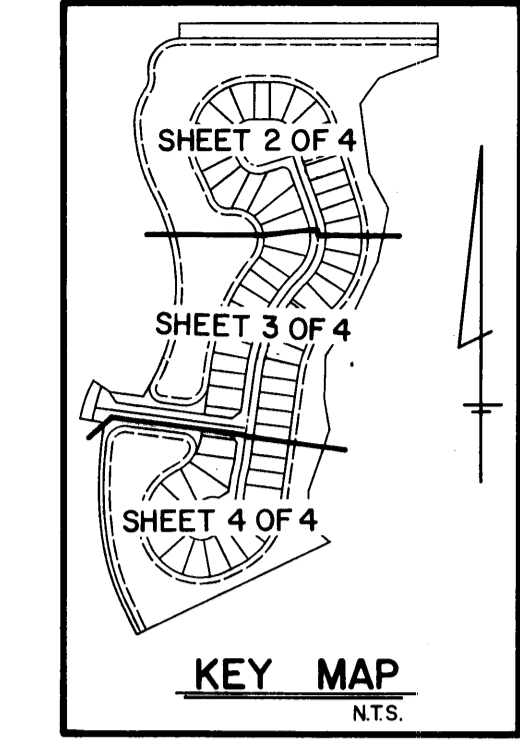

I, MARSHA STILLER, CLERK OF THE CIRCUIT COURT OF MARTIN COUNTY, FLORIDA, HEREBY CERTIFY THAT THIS PLAT WAS FILED FOR RECORD IN PLAT BOOK 11, PAGE 94, MARTIN COUNTY, FLORIDA, PUBLIC RECORDS, THIS DAY OF _____ A.D. 19____.
MARSHA STILLER, CLERK OF CIRCUIT COURT MARTIN COUNTY, FLORIDA
By: _____ DEPUTY CLERK
FILE NO. _____

SOUTHWEST WATERFALL BOULEVARD
AT THE MEADOWS
(P.B. II, PGS. 23)

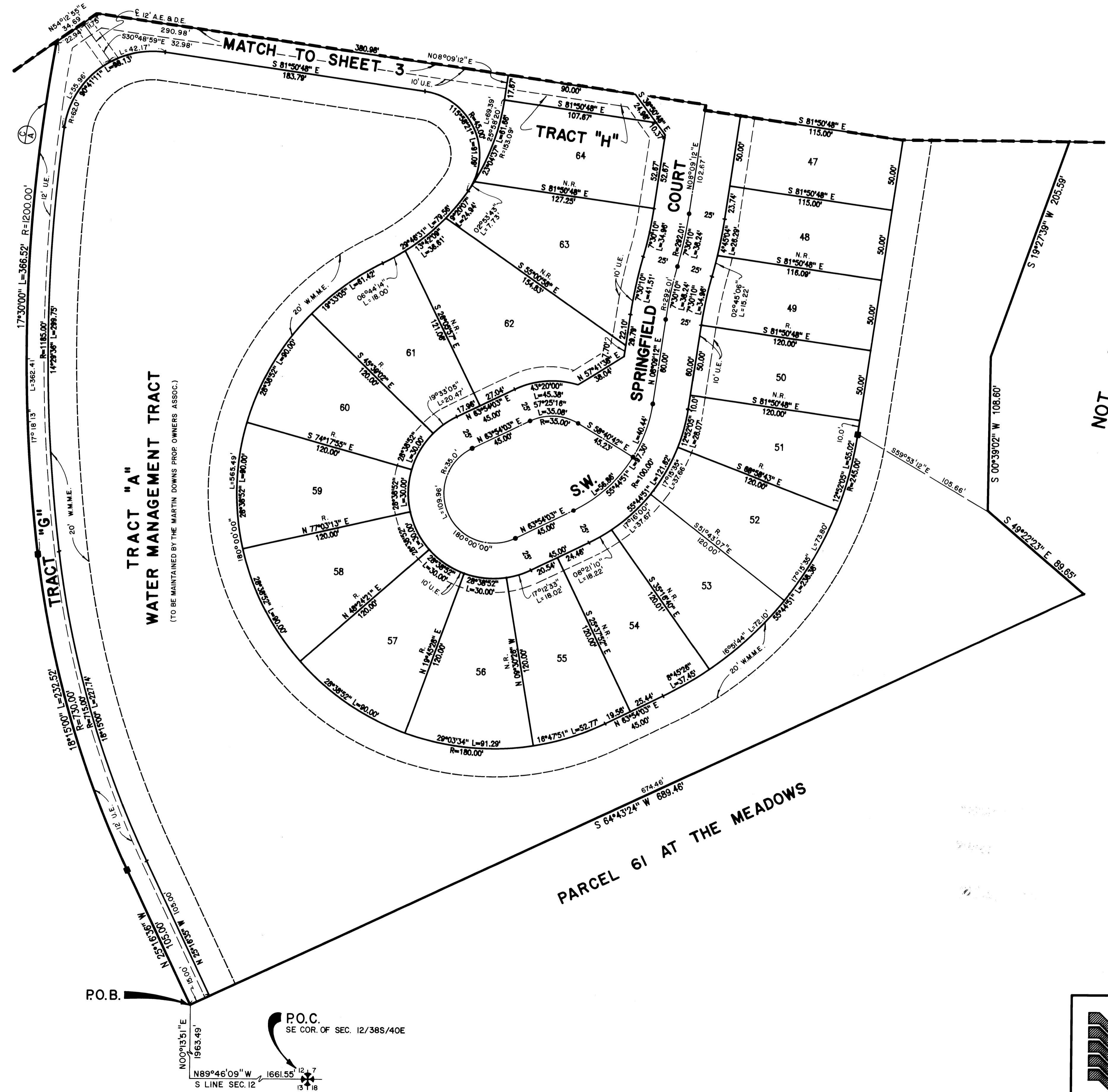

NOT PLATTED

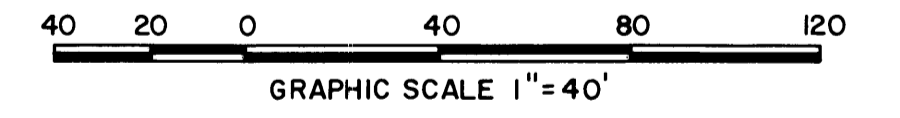

Landmark Surveying & Mapping Inc.
1850 FOREST HILL BOULEVARD
PH. (305)433-5405 SUITE 100 W.P.B. FLORIDA

PARCEL 60 AT THE MEADOWS